

**DELIVERED**  
**June / July 2014**



1201 Maple Creek Lane, New London, WI. 54961  
PH: 920-779-9913 / FX: 920-779-9914  
ejmetals.com



## **Nuclear Emergency Hose Deployment Modules**

**7-Compartment Rolled Hose Main Module**  
**8-Modules**



**Hose Reel Storage Module**  
**8-Modules**

**United States Nuclear Regulatory Commission**

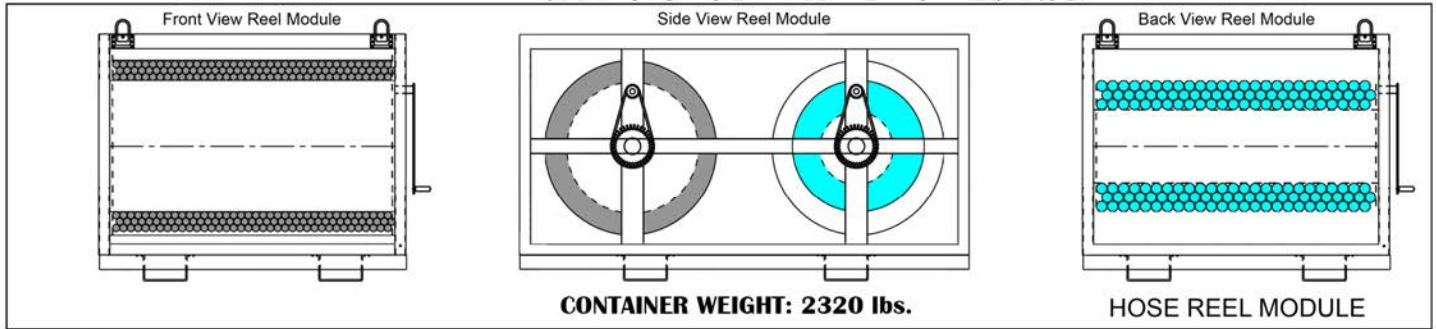

**FEATURES**

- 3" x 3" x .25" Extruded Aluminum Tube Frame
- Welded Frame
- .125" Plate Floors & Panels
- Welded Floors
- Bolted Top & Side Panels
- Manual Re-Wind Reels
- Solid Steel Shafts
- Pillow Block Bearings
- Hinged Hose Deployment Panels
- "D" Ring Closures
- No Tools Needed Operation
- 84" Wide x 123" Long x 56.50" Tall
- ISO Corners
- Lifting Eyes
- Fork Lift Pockets

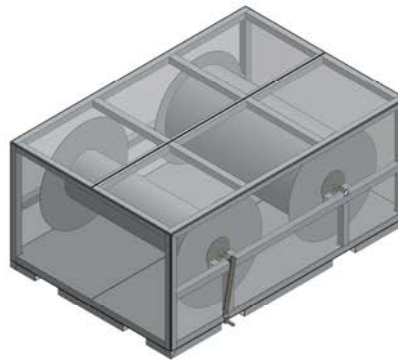

**TRANSPORTABLE**  
 Truck / Trailer  
 Fixed Wing Aircraft  
 Rotary Wing Aircraft  
 Fork Lift

**HOSE LOAD**

- 600' x 1.5" UHP Hose
- 200' x 2.5" Suction Hose
- 2-Manual Hand Cranks



**APPROVED**

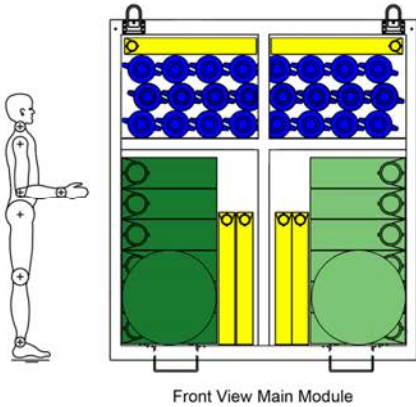

Front View Main Module

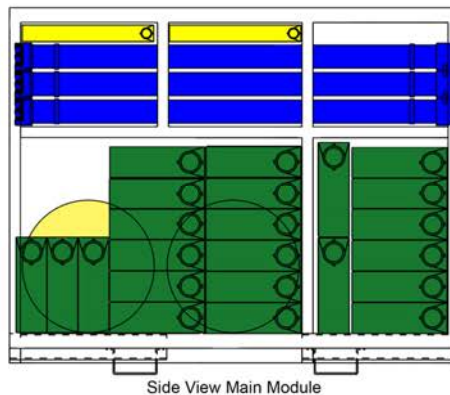

Side View Main Module

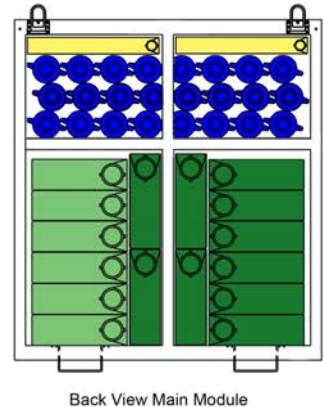

Back View Main Module

**CONTAINER WEIGHT: 6845 lbs.**

**FEATURES**

- 3" x 3" x .25" Extruded Aluminum Tube Frame
- Welded Frame
- .25" Plate Floors & Panels
- Welded Floors & Panels
- Pan Style Compartment Access Doors
- "D" Ring Closures
- Bolted Top Sections
- 84" Wide x 123" Long x 96" Tall
- ISO Corners
- Lifting Eyes
- Fork Lift Pockets

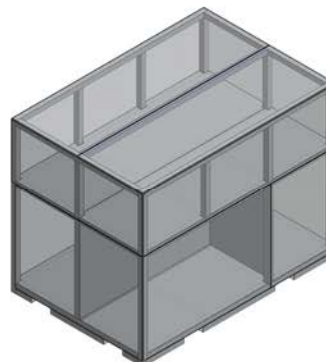

**HOSE LOAD**

- 48-Sections of 50' x 5" Supply Line
- 9-Sections of 100' x 2.5" Supply Line
- 24-Sections of 10' x 6" HSH

**MISC. FITTINGS**

- 5" x 2.5" Wye Gate
- 5" Floating Strainers
- Hydrant Wrenches
- 5" Storz Adapters
- 1.5" UHP Hose Couplers